



# Digimatic Caliper Gage

## SERIES 209 — Internal, External and Tube Thickness Measurement Type

Versatile internal and external measuring gages for hole diameter, groove depth, tube thickness, and hard-to-reach dimensions.

The Digimatic Caliper Gages provide error-free LCD readings as well as data output for SPC analysis.

### Technical Data

Accuracy: Refer to the list of specifications (excluding quantizing error)  
 Resolution: 0.01mm or 0.005mm  
 Display: LCD  
 Stem dia.: 8mm (ISO/JIS type) or 3/8" (ANSI/AGD type)  
 Contact points: Carbide ball with M2.5x0.45 (ISO/JIS type)  
 Steel ball with #4-48UNF (ANSI/AGD type)  
 Battery: CR-123A or DL-123A (1 pc.)  
 Battery life: Approx. 350 hours  
 Dust/Water protection level: IP63

### Functions

Zeraset, Preset, Auto power OFF, Data hold, Max/Min value holding, Data output

### Optional Accessories

21JAA300: SPC cable (2m)

### Internal measurement type



209-506M

Unit: mm

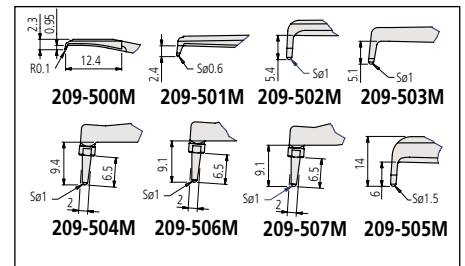

### External measurement type



209-521M

Unit: mm

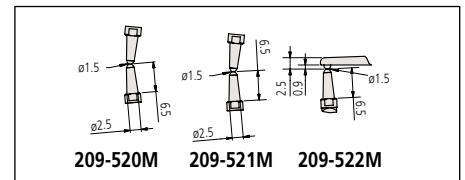

## SPECIFICATIONS

### Metric

Range	Order No.	Resolution	Accuracy	Measuring force	Dimension (L)	Remarks
2.5 - 12.5mm	209-500M	0.005mm	±15µm	0.7 - 1.2N	12mm	Internal measurement type
5 - 25mm	209-501M	0.01mm	±20µm	0.9 - 1.4N	22mm	Internal measurement type
10 - 30mm	209-502M	0.01mm	±20µm	0.9 - 1.4N	47mm	Internal measurement type
20 - 40mm	209-503M	0.01mm	±20µm	1.1 - 1.7N	50mm	Internal measurement type
30 - 50mm	209-504M	0.01mm	±20µm	1.1 - 1.7N	55mm	Internal measurement type
15 - 55mm	209-505M	0.02mm	±40µm	1.2 - 1.7N	120mm	Internal measurement type
50 - 70mm	209-506M	0.01mm	±20µm	1.1 - 1.7N	55mm	Internal measurement type
70 - 90mm	209-507M	0.01mm	±20µm	1.1 - 1.7N	55mm	Internal measurement type
0 - 10mm	209-520M	0.005mm	±10µm	0.6 - 1.2N	10mm	External measurement type
0 - 20mm	209-521M	0.01mm	±20µm	0.7 - 1.3N	46mm	External measurement type
0 - 20mm	209-522M	0.01mm	±20µm	0.7 - 1.3N	46mm	External measurement type

## DIMENSIONS

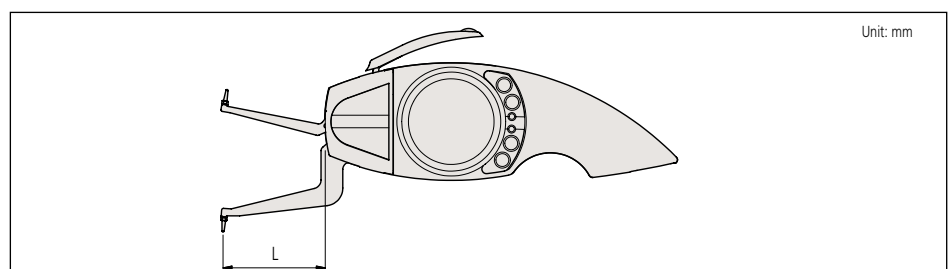

Unit: mm

# Dial Caliper Gage

## SERIES 209 — Internal Measurement Type

These Dial Caliper Gages are comparison gages, and should be used in conjunction with a Setting Ring or a micrometer. The

caliper is spring loaded and makes point contact at constant measuring force.



209-152



209-122

### SPECIFICATIONS

Metric								
Range	Order No.	Graduation	Dial face	Accuracy	Measuring force	Dimension [L / A (max) / B (min)]		
6 - 18mm	209-122	0.01mm	0-100-100	±40µm	1.2N or less	40mm	1.0mm	2.5mm
10 - 22mm	209-123	0.01mm	0-100-100	±40µm	1.2N or less	40mm	2.0mm	2.5mm
20 - 32mm	209-124	0.01mm	0-100-100	±40µm	1.2N or less	40mm	4.2mm	2.5mm
5 - 15mm	209-152	0.01mm	0-100	±25µm	1.2N or less	30mm	2.0mm	0.7mm
10 - 20mm	209-153	0.01mm	0-100	±25µm	1.2N or less	30mm	5.0mm	0.7mm
10 - 30mm	209-171	0.01mm	0-100-100	±25µm	1.2N or less	65mm	5.2mm	0.7mm
20 - 40mm	209-172	0.01mm	0-100-100	±25µm	1.2N or less	65mm	9.5mm	0.7mm



209-650



209-608



209-609



209-884



209-896

### SPECIFICATIONS

Metric								
Range	Order No.	Graduation	Accuracy	Measuring force	Contact point	Dimension [L / A (max) / B (min)]		
2.5 - 7.5mm	209-650	0.005mm	±15µm	1.7N or less	R0.1mm	12.4mm	0.7mm	0.6mm
5 - 10mm	209-651	0.005mm	±15µm	1.7N or less	ø0.6mm	27mm	2.3mm	1.9mm
5 - 15mm	209-652	0.01mm	±20µm	1.7N or less	ø0.6mm	23mm	2.3mm	1.7mm
10 - 20mm	209-653	0.01mm	±20µm	1.7N or less	ø1.0mm	60.6mm	4.5mm	1.8mm
10 - 30mm	209-608	0.01mm	±30µm	1.5N or less	ø1.0mm	80mm	5.0mm	1.7mm
20 - 30mm	209-654	0.01mm	±20µm	1.7N or less	ø1.0mm	60.6mm	4.5mm	2.0mm
20 - 40mm	209-609	0.01mm	±30µm	1.5N or less	ø1.0mm	80mm	6.5mm	2.3mm
30 - 40mm	209-655	0.01mm	±20µm	1.7N or less	ø1.0mm	60.6mm	4.5mm	2.0mm
30 - 50mm	209-600	0.01mm	±30µm	1.5N or less	ø1.0mm	80mm	6.5mm	2.5mm
40 - 50mm	209-656	0.01mm	±20µm	1.7N or less	ø1.0mm	60.6mm	4.5mm	1.8mm
40 - 60mm	209-884	0.01mm	±30µm	1.5N or less	ø1.0mm	80mm	9.0mm	2.3mm
50 - 70mm	209-885	0.01mm	±30µm	1.5N or less	ø1.0mm	80mm	8.0mm	3.7mm
60 - 80mm	209-886	0.01mm	±30µm	1.5N or less	ø1.0mm	80mm	8.0mm	3.7mm
70 - 90mm	209-887	0.01mm	±30µm	1.5N or less	ø1.0mm	80mm	8.0mm	3.7mm
80 - 100mm	209-888	0.01mm	±30µm	1.5N or less	ø1.0mm	80mm	8.0mm	3.7mm
15 - 65mm	209-896	0.05mm	±50µm	2.0N or less	ø1.5mm	175mm	5.0mm	2.1mm
40 - 90mm	209-897	0.05mm	±50µm	2.0N or less	ø2.0mm	175mm	10.0mm	3.8mm
70 - 120mm	209-898	0.05mm	±50µm	2.0N or less	ø2.0mm	175mm	8.0mm	3.8mm

### DIMENSIONS

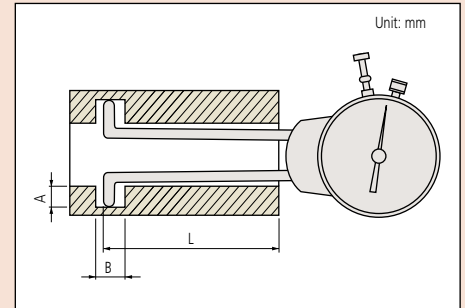

### DIMENSIONS

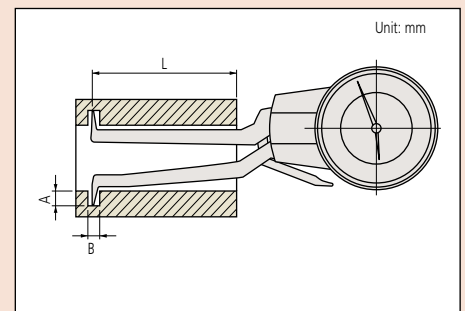

# Dial Caliper Gage

## SERIES 209 — External Measurement Type

### Application

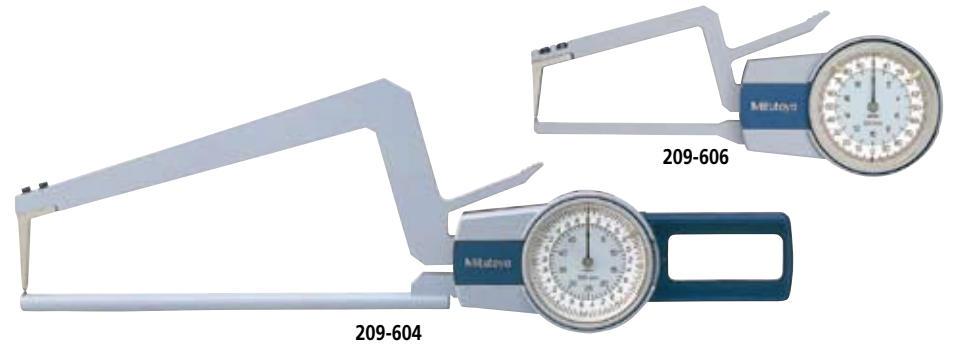
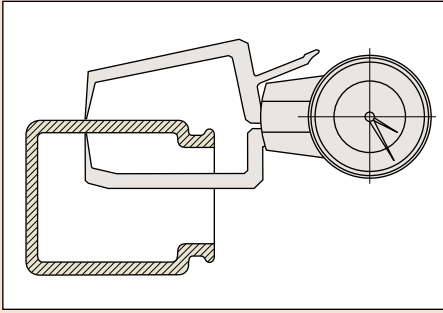

### Type of Contact Points

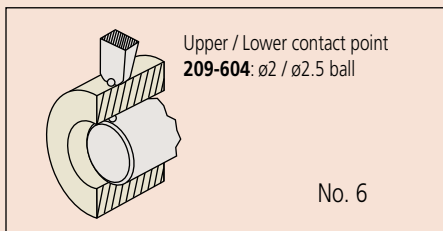
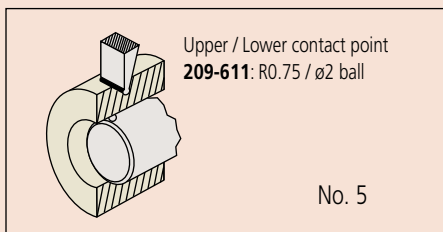
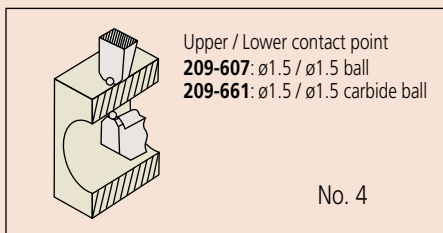
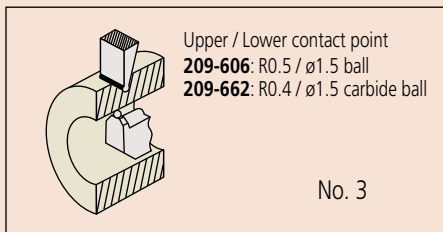
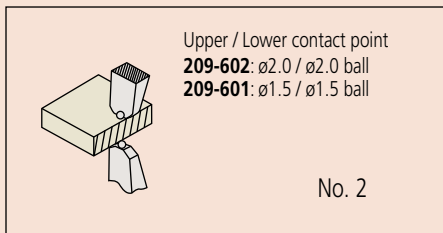
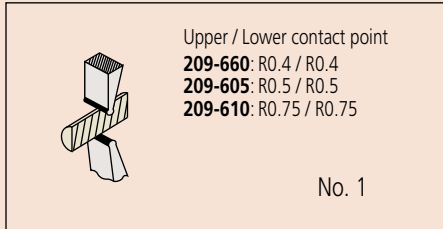

### DIMENSIONS

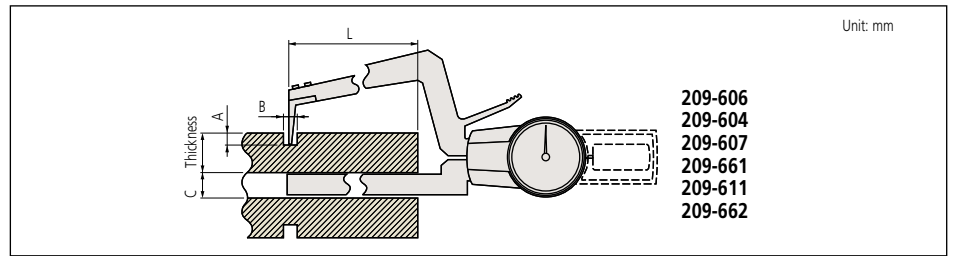

### DIMENSIONS

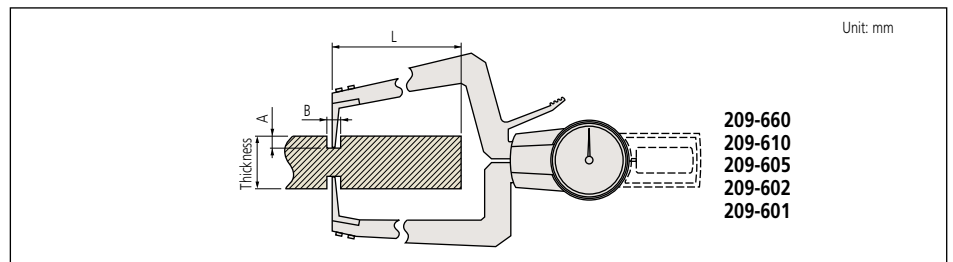

### SPECIFICATIONS

Metric						
Range	Order No.	Graduation	Accuracy	Measuring force	Contact point	Dimension [L / A (max) / B (min) / C (min)]
0 - 10mm	209-660	0.01mm	±20µm	1.3N or less	No. 1	60.5mm 7mm 2mm —
0 - 10mm	209-661	0.01mm	±20µm	1.3N or less	No. 4	60.5mm 7mm 2mm 3mm
0 - 10mm	209-662	0.01mm	±20µm	1.3N or less	No. 3	60.5mm 7mm 2mm 3mm
0 - 20mm	209-605	0.01mm	±30µm	1.5N or less	No. 1	80mm 10mm 5mm —
0 - 20mm	209-601	0.01mm	±30µm	1.5N or less	No. 2	80mm 10mm 5mm —
0 - 20mm	209-606	0.01mm	±30µm	1.5N or less	No. 3	80mm 10mm 5mm 10mm
0 - 20mm	209-607	0.01mm	±30µm	1.5N or less	No. 4	80mm 10mm 5mm 10mm
0 - 50mm	209-610	0.05mm	±50µm	1.8N or less	No. 1	170mm 20mm 7mm —
0 - 50mm	209-602	0.05mm	±50µm	1.8N or less	No. 2	170mm 20mm 7mm —
0 - 50mm	209-611	0.05mm	±50µm	1.8N or less	No. 5	170mm 20mm 7mm 12mm
0 - 50mm	209-604	0.05mm	±50µm	1.8N or less	No. 6	170mm 20mm 7mm 12mm